

# eW 300 IEM G2

Instructions for use

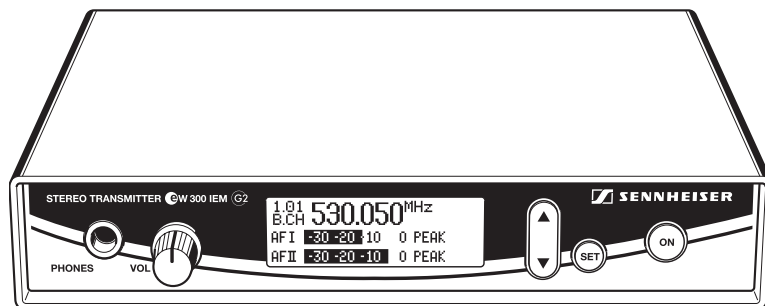
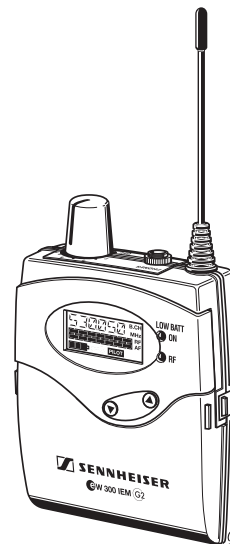
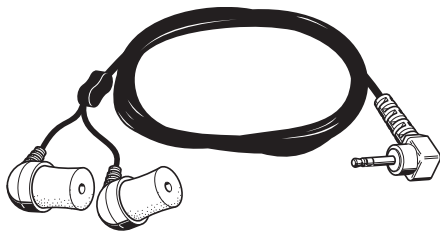

## **Thank you for choosing Sennheiser!**

We have designed this product to give you reliable operation over many years. Over half a century of accumulated expertise in the design and manufacture of high-quality electro-acoustic equipment have made Sennheiser a world-leading company in this field.

Please take a few moments to read these instructions carefully, as we want you to enjoy your new Sennheiser products quickly and to the fullest.

# Contents

The ew 300 IEM G2 system .....	42
The channel bank system .....	42
Safety instructions .....	43
System components .....	43
Overview of operating controls .....	44
SR 300 IEM G2 stereo transmitter .....	44
EK 300 IEM G2 stereo receiver .....	45
Indications and displays on the transmitter .....	46
Indications and displays on the receiver .....	46
Preparing the components for use .....	48
SR 300 IEM G2 stereo transmitter .....	48
EK 300 IEM G2 stereo receiver .....	51
Using the components .....	52
Switching the components on/off .....	52
Adjusting the volume .....	52
Adjusting the balance .....	53
Activating/deactivating the lock mode .....	53
Attaching the receiver to clothing .....	53
The operating menu .....	54
The buttons .....	54
Overview of menus .....	55
Working with the operating menu .....	55
Operating menu of the stereo transmitter .....	57
Operating menu of the stereo receiver .....	59
Adjustment tips for the operating menu .....	62
Switching between channel banks .....	62
Switching between the channels in a channel bank .....	62
Selecting the frequencies to be stored in the channel bank "U" .....	62
Scanning the channel banks for free channels (receiver only) .....	62
Multi-channel operation .....	63
Adjusting the squelch threshold (receiver only) .....	63
Stereo/FOCUS selection (receiver only) .....	64
Limiting the volume at the headphone output (receiver only) .....	64
Activating/deactivating the frequency boost (receiver only) .....	64
Adjusting the sensitivity (transmitter only) .....	64
Selecting the standard display .....	65
Entering a name .....	65
Loading the factory-preset default settings .....	66
Activating/deactivating the pilot tone evaluation (receiver only) .....	66
Adjusting the contrast of the graphic display (transmitter only) .....	66
Stereo/Mono selection (transmitter only) .....	66
Activating/deactivating the lock mode .....	67
Exiting the operating menu .....	67
Troubleshooting .....	68
Error checklist .....	68
Recommendations and tips .....	69
Care and maintenance .....	69
Additional information .....	70
HDX noise reduction .....	70
Wireless transmission systems .....	70
Squelch .....	71
Specifications .....	72
Connector assignment .....	73
Accessories .....	73

## The ew 300 IEM G2 system

With the Sennheiser evolution wireless in-ear monitoring system ew 300 IEM G2 (suitable for both stage and broadcast use), musicians, video and sound amateurs, reporters/broadcasters, etc. can directly monitor the received sound signals without troublesome cables or monitor speakers being required. In addition, the system can also be used for any application where talkback signals are to be transmitted.

The evolution wireless in-ear monitoring system ew 300 IEM G2 is a high-quality state-of-the-art RF transmission systems with a high level of operational reliability and ease of use. Transmitter and receiver permit wireless transmission with studio-quality sound. The excellent transmission reliability of the ew 300 IEM G2 system is based on the use of

- further optimized PLL synthesizer and microprocessor technology,
- the **HDX** noise reduction system,
- the pilot tone squelch control (during stereo operation),
- and the scan function for scanning the channel banks for free channels.

### The channel bank system

The ew 300 IEM G2 system is available in five UHF frequency ranges with 1440 transmission/receiving frequencies per frequency range. Please note: Frequency usage is different for each country. Your Sennheiser agent will have all the necessary details on the available legal frequencies for your area.

Range A: 518 to 554 MHz

Range B: 626 to 662 MHz

Range C: 740 to 776 MHz

Range D: 786 to 822 MHz

Range E: 830 to 866 MHz

Transmitter and receiver have nine channel banks with up to 12 switchable channels each.

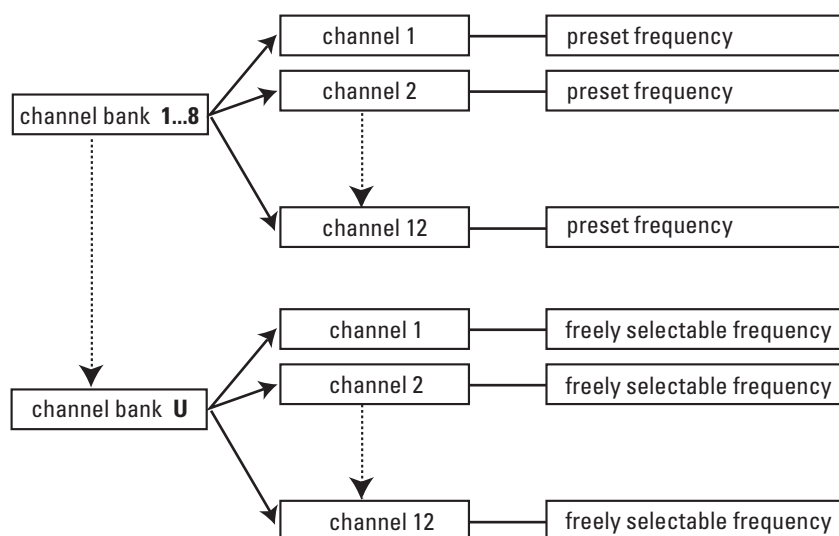

The channel banks "1" to "8" have switchable channels that are factory-preset to a transmission/receiving frequency (see enclosed frequency table). These transmission/receiving frequencies cannot be changed but have been preset so that e.g. country-specific regulations on frequency usage are taken

into account. The channel bank "U" (user bank) has up to 12 switchable channels to store your selection out of 1440 transmission/receiving frequencies that are freely selectable within the preset frequency range.

An advantage of the factory-preset frequencies is that

- the system is ready for immediate use after switch-on,
- several in-ear monitoring systems can be operated simultaneously on the preset channels without causing intermodulation interference.

## Safety instructions

Never open electronic units! If units are opened by customers in breach of this instruction, the warranty becomes null and void.

Keep the units away from central heating radiators and electric heaters. Never expose them to direct sunlight.

Use the units in dry rooms only.

Use a damp cloth for cleaning the units. Do not use any cleansing agents or solvents.

### Attention! High Volume!



This is a professional transmission system. Commercial use is subject to the rules and regulations of the trade association responsible. Sennheiser, as the manufacturer, is therefore obliged to expressly point out possible health risks arising from use.

This system is capable of producing sound pressure exceeding 85 dB(A). 85 dB(A) is the sound pressure corresponding to the maximum permissible volume which is by law (in some countries) allowed to affect your hearing for the duration of a working day. It is used as a basis according to the specifications of industrial medicine. Higher volumes or longer durations can damage your hearing. At higher volumes, the duration must be shortened in order to prevent damage. The following are sure signs that you have been subjected to excessive noise for too long a time:

- You can hear ringing or whistling sounds in your ears.
- You have the impression (even for a short time only) that you can no longer hear high notes.

## System components

The system consists of:

- 1 EK 300 IEM G2 stereo receiver
- 1 SR 300 IEM G2 stereo transmitter
- 2 batteries
- 1 telescopic antenna for SR 300 IEM G2
- 1 NT 2-1 mains unit
- IE 3 in-ear headphones
- Instructions for use

# Overview of operating controls

## SR 300 IEM G2 stereo transmitter

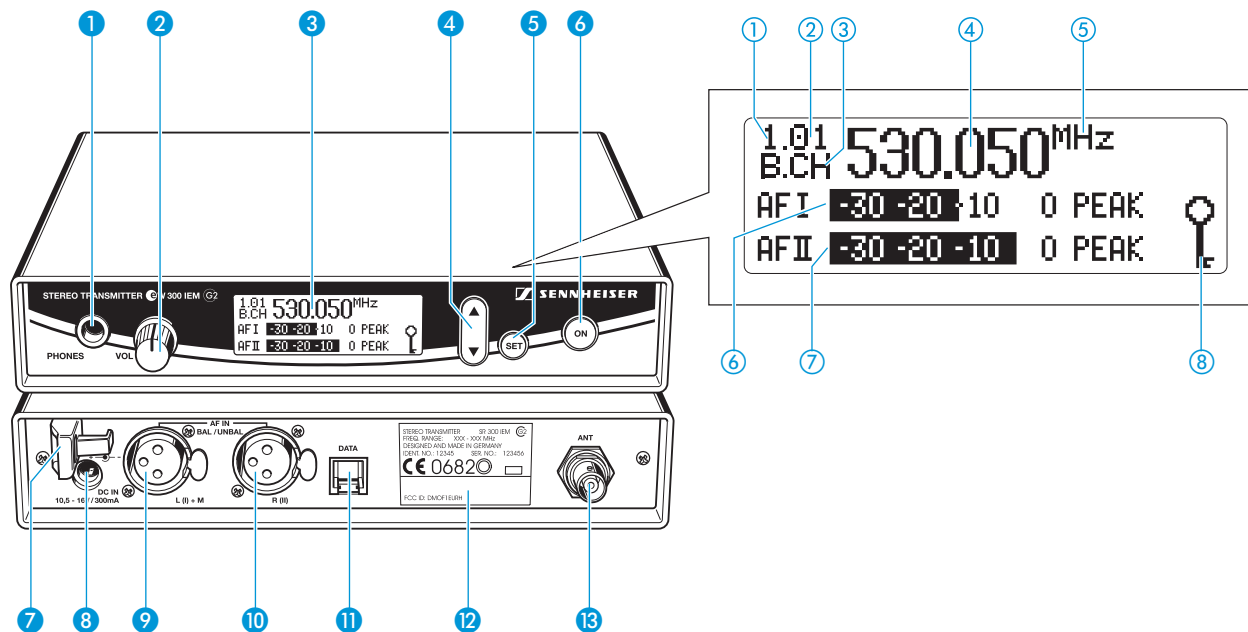

### Operating controls

- 1 Headphone output (PHONES), 1/4" (6.3 mm) jack socket
- 2 Headphone volume control (VOL)
- 3 Graphic display, backlit
- 4 ▼/▲ rocker button, backlit
- 5 SET button, backlit
- 6 ON button, backlit (serves as the ESC (cancel) key in the operating menu)
- 7 Cable grip for power supply DC cable
- 8 DC socket for connection of mains unit (DC IN)
- 9 Audio input (AF IN BAL/UNBAL), XLR-3F socket (left and MONO)
- 10 Audio input (AF IN BAL/UNBAL), XLR-3F socket (right)
- 11 Service interface (DATA)
- 12 Type plate
- 13 Antenna output (ANT), BNC socket

### Graphic display panel

- 1 Display for the current channel bank "1...8, U"
- 2 Display for the current channel number "1...12"
- 3 "B.CH" – abbreviation for channel bank and channel number
- 4 Alphanumeric display
- 5 "MHz" – appears when the frequency is displayed
- 6 Level display for audio signal "AF I" (left and MONO), with "PEAK" warning
- 7 Level display for audio signal "AF II" (right), with "PEAK" warning
- 8 Lock mode icon (lock mode is activated)

#### Note:

For further illustrations and examples of the different standard displays, please refer to the section "Selecting the standard display" on page 65.

## EK 300 IEM G2 stereo receiver

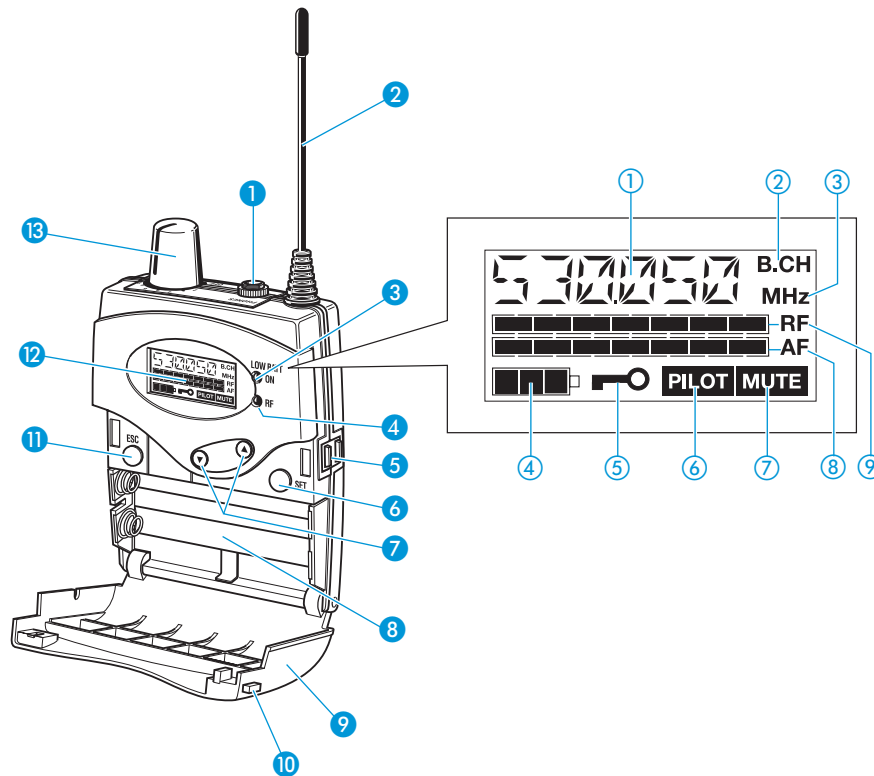

### Operating controls

- ① Headphone output (PHONES), 3.5 mm jack socket
- ② Antenna
- ③ Red LED for operation and battery status indication (ON/LOW BAT)
- ④ Green LED for RF signal indication (RF)
- ⑤ SET button
- ⑥ ▼/▲ rocker button (DOWN/UP)
- ⑦ Battery compartment
- ⑧ Battery compartment cover
- ⑨ Unlocking button
- ⑩ ESC button
- ⑪ LC display
- ⑫ On/off/volume control

### LC display panel

- ① Alphanumeric display
- ② "B.CH" – appears when the channel bank and the channel number are displayed
- ③ "MHz" – appears when the frequency is displayed
- ④ 4-step battery status display
- ⑤ Lock mode icon (lock mode is activated)
- ⑥ "PILOT" display (pilot tone evaluation is activated)
- ⑦ "MUTE" display (audio output is muted)
- ⑧ 7-step level display for received audio signal "AF"
- ⑨ 7-step level display for received RF signal "RF"

## Indications and displays on the transmitter

### Modulation display

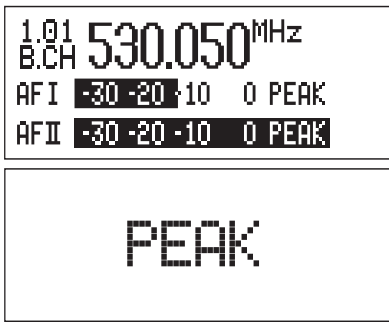

The level display for audio signal "AF" shows the modulation of the transmitter.

When the transmitter's audio input level is excessively high, the level display for audio signal "AF" shows full deflection.

When the transmitter is overmodulated frequently or for an extended period of time, the text "PEAK" (backlit in red) flashes in alternation with the standard display.

### Button backlighting

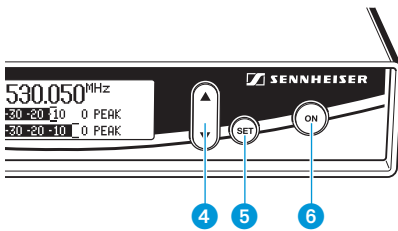

During standby operation, the ON button 6 is backlit in red. When the transmitter is switched on, the SET button 5 and the ▲/▼ button 4 are additionally backlit in green.

## Indications and displays on the receiver

### Operation and battery status indication

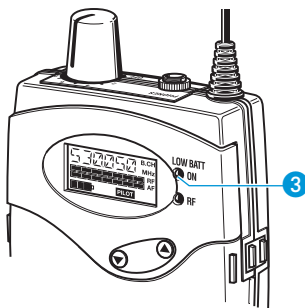

The red LED (LOW BAT/ON) 3 provides information on the current operating state of the receiver:

Red LED lit up: The receiver is switched on and the capacity of the batteries/accupack BA 2015 is sufficient.

Red LED flashing: The batteries are/the accupack BA 2015 is going flat (LOW BAT)!

In addition, the 4-step battery status display 4 on the display panel provides information on the remaining battery/accupack BA 2015 capacity:

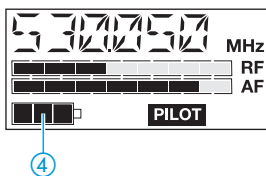

3 segments: capacity approx. 100 %

2 segments: capacity approx. 70 %

1 segment: capacity approx. 30 %

Battery icon flashing: LOW BAT

### Modulation display of the receiving transmitter

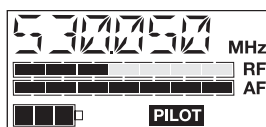

The level display for audio signal "AF" shows the modulation of the transmitter.

When the transmitter's audio input level is excessively high (AF peak), the receiver's level display for audio signal "AF" shows full deflection.



### “MUTE” display

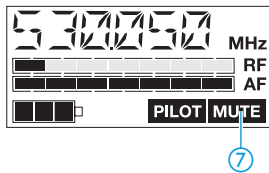

The “MUTE” display ⑦ appears on the display panel when the RF signal of the received transmitter is too weak.

### “PILOT” display

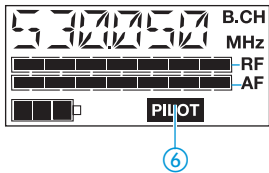

The “PILOT” display ⑥ appears on the display panel when the pilot tone evaluation is activated (see “Activating/deactivating the pilot tone evaluation (receiver only)” on page 66).

### RF signal indication

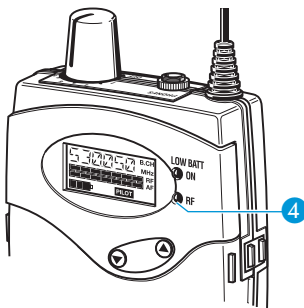

The green LED (RF) ④ at the front of the receiver lights up when an RF signal is being received.

However, the green LED (RF) does not light up when the audio output is muted because

- the RF signal of the received transmitter is too weak,
- the transmitter is set to mono operation and the receiver’s pilot tone evaluation is activated.

### Display backlighting

After pressing a button, the display remains backlit for approx. 15 seconds.

# Preparing the components for use

## SR 300 IEM G2 stereo transmitter

### Mounting the transmitter feet

To ensure that the transmitter cannot slip on the surface on which it is placed, four self-adhesive soft rubber feet are supplied.

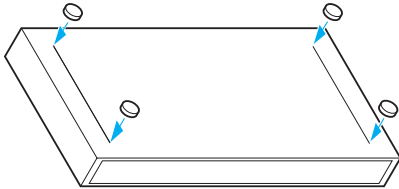

- ▶ Ensure that the base of the transmitter is clean and free from grease before mounting the rubber feet.
- ▶ Fix the rubber feet to the base of the transmitter by peeling of the safety paper and fitting them as shown in the diagram on the left.

### Attention!

Some furniture surfaces have been treated with varnish, polish or synthetics which might cause stains when they come into contact with other synthetics. Despite a thorough testing of the synthetics used by us, we cannot rule out the possibility of staining.

### Connecting the antenna

The supplied telescopic antenna can be mounted quickly and easily to the rear of the transmitter and is suitable for all applications where – good transmission conditions provided – a wireless transmission system is to be used without a large amount of installation work.

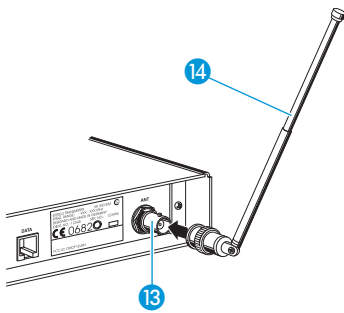

- ▶ Connect the telescopic antenna 14 to the BNC socket 13 at the rear of the transmitter.
- ▶ Pull the end cap to extend the telescopic antenna 14.

Use a remote antenna (available as an accessory) when the transmitter position is not the best antenna position for optimum transmission.

### Connecting the mains unit

The transmitter is powered via a mains unit.

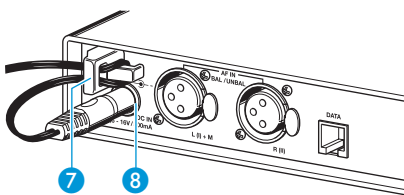

- ▶ Pass the cable through the cable grip 7.
- ▶ Insert the DC connector on the mains cable into the DC socket 8.

### Connecting the amplifier/mixing console

- ▶ Connect the amplifier/mixing console to the XLR-3F sockets 9 (left and MONO) or 10 (right).

Both balanced and unbalanced connection is possible (see "Connector assignment" on page 73).

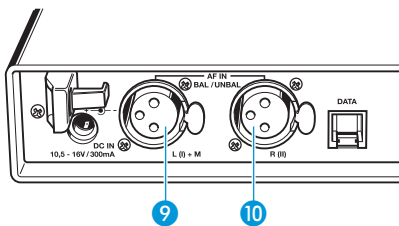

### Note:

Any unit that is only suitable for mono operation must be connected to XLR-3F socket 9. In this case, set the transmitter to mono operation via the menu.

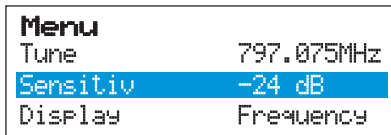

- ▶ Via the "Sensitiv" menu, adjust the transmitter's input sensitivity (see "Adjusting the sensitivity (transmitter only)" on page 64).

### Connecting the headphones/monitoring the audio signal

To monitor the audio signal, connect headphones with a ¼" (6.3 mm) jack plug to the headphone output (PHONES) ①.

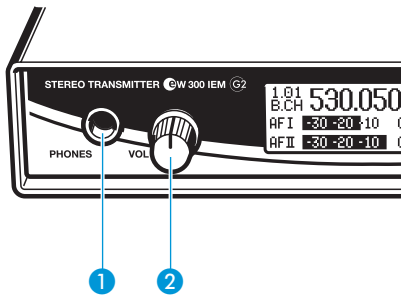

#### Attention! High volume!

Even short exposure to high volume levels will damage your hearing! Set the volume for the connected headphones to the minimum before putting the headphones on.

- ▶ First, set the volume control ② to the lowest volume by turning it to the left as far as possible. Then gradually turn up the volume.

#### Volume up? – NO!

When people use headphones, they tend to choose a higher volume than with loudspeakers. Listening at high volume levels for long periods can lead to permanent hearing defects. Please protect your hearing, Sennheiser headphones have an excellent sound quality even at low volumes.

### Service interface

The service interface ⑪ is only required for servicing purposes.

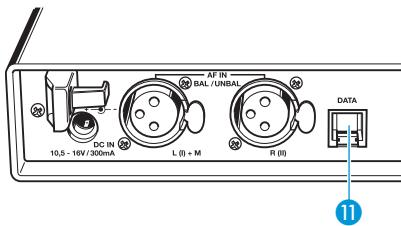

### 19" rack adapter and antenna mount

For mounting one or two transmitters into a 19" rack, you require the GA 2 rack adapter (available as an accessory). The GA 2 rack adapter consists of:

- 2 rack mount "ears" ⑮
- 1 connecting bar ⑯
- 1 connecting plate ⑰
- 2 covering plugs ⑱ for antenna holes
- 12 recessed head screws M 3x6
- 2 recessed head screws M 6x10

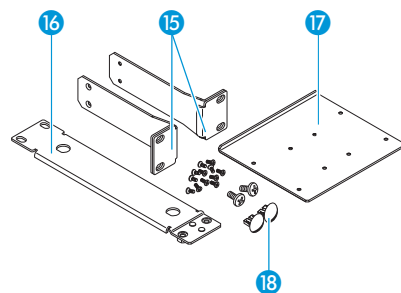

When mounting only one transmitter into a rack, you can use the AM 2 antenna mount (available as an accessory) to mount the transmitter's antenna connection to the front of the GA 2 rack adapter. The AM 2 antenna mount consists of:

- 2 BNC extension cables (screw-in BNC socket ⑲ to BNC connector ⑳)
- 2 plains washers
- 2 nuts

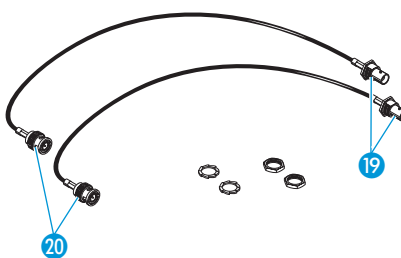

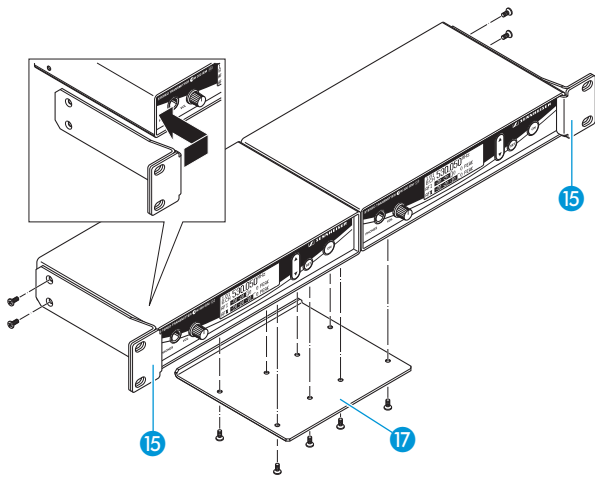

To mount two transmitters into a rack:

- ▶ Place the two transmitters side by side onto a flat surface, their bottom sides facing upwards.
- ▶ Align the connecting plate 17 over the holes in the bottom sides of the transmitters.
- ▶ Secure the connecting plate 17 using eight of the supplied recessed head screws (M 3x6).
- ▶ Hook the two rack mount "ears" 15 to the front panels of the transmitters.
- ▶ Secure the rack mount "ears" to the transmitters using two of the supplied recessed head screws (M 3x6) respectively.
- ▶ Slide the transmitters into the 19" rack.
- ▶ Secure the rack mount "ears" to the rack.

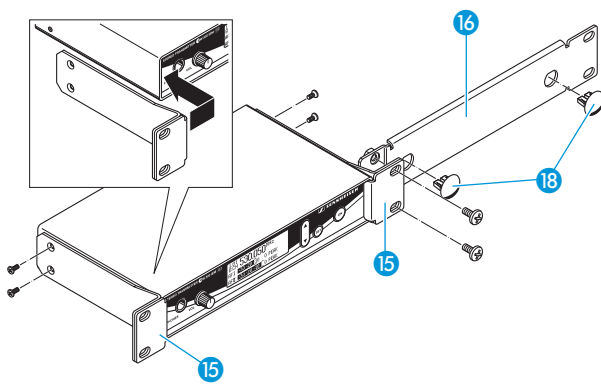

When mounting only one transmitter into a rack, use the connecting bar 16 instead of the second transmitter.

- ▶ Hook the two rack mount "ears" 15 to the front panels of the transmitter.
- ▶ Secure the rack mount "ears" to the transmitter using two of the supplied recessed head screws (M 3x6) respectively.
- ▶ Secure the connecting bar 16 to one of the rack mount "ears" 15 using two of the supplied recessed head screws (M 6x10).
- ▶ If you are not front mounting the antennas, insert the two covering plugs 18 into the antenna holes of the connecting bar.
- ▶ Slide the transmitter into the 19" rack.
- ▶ Secure the rack mount "ears" to the rack.

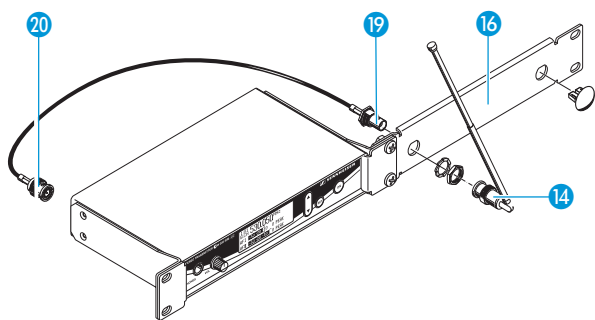

To mount the transmitter's antenna connection to the front of the GA 2 rack adapter using the AM 2 antenna mount:

- ▶ Screw the BNC socket 19 of the BNC extension cables to the connecting bar 16 using the supplied plain washer and nut.
- ▶ Connect the BNC connector 20 to the BNC socket 13 at the rear of the transmitter.
- ▶ Slide the transmitter into the 19" rack.
- ▶ Secure the rack mount "ears" to the rack.
- ▶ Connect the telescopic antenna 14 to the BNC socket 19.
- ▶ Pull the end cap to extend the telescopic antenna.

## EK 300 IEM G2 stereo receiver

### Inserting and replacing the batteries

For powering the EK 300 IEM G2 receiver, two 1.5 V AA size batteries are required.

- ▶ Press the two unlocking buttons **10** and open the battery compartment cover **9**.
- ▶ Insert the two batteries as shown in the diagram on the left. Please observe correct polarity when inserting the batteries.
- ▶ Close the battery compartment. The battery compartment cover **9** locks into place with an audible click.

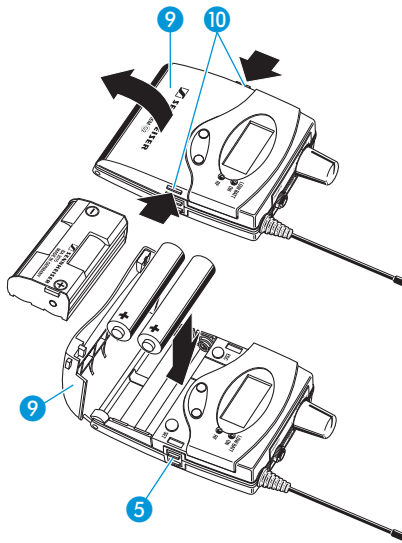

### Inserting and charging the accupack

The receiver can also be powered via the rechargeable Sennheiser BA 2015 accupack. Insert the accupack into the battery compartment as described above. The transmitter has two charging contacts **5** and a sensing contact on its short sides. The accupack can be recharged while remaining in the transmitter. Insert the transmitter into the L 2015 charger (see operating manual of the L 2015 charger).

#### Note:

For accupack operation of the receiver, only use the BA 2015 accupack in order to ensure optimum operational reliability. For charging the accupack, only use the L 2015 charger. Both the accupack and the charger are available as accessories. The accupack is fitted with an integrated sensor which is – via a third contact – monitored by the electronics of the receiver and the charger. The sensor is necessary for the following control purposes:

- The taking into account of the different voltage characteristics of primary cells (batteries) and accupacks. The battery status indications on the displays, the transmission of transmitter battery status information to the rack-mount receivers and the switch-off thresholds at the end of the operating time are corrected correspondingly. Due to the missing sensor, individual rechargeable battery cells will not be identified as accupacks.
- The monitoring of the accupack temperature during charging in the L 2015 charger.
- The prevention of improper charging of inserted primary cells (batteries). Due to the missing sensor, individual rechargeable battery cells will also not be charged in the L 2015 charger.

### Connecting the headphones

- ▶ If you use the receiver as part of the monitoring system, connect the supplied in-ear headphones or any Sennheiser stereo headphones with 3.5 mm stereo jack plug to the headphone output (PHONES) **1**.

#### Attention! High volume!

Even short exposure to high volume levels will damage your hearing! Set the volume for the connected headphones to the minimum before putting the headphones on.

- ▶ First, set the volume control **2** to the lowest volume by turning it to the left as far as possible. Then gradually turn up the volume.

#### Volume up? – NO!

When people use headphones, they tend to choose a higher volume than with loudspeakers. Listening at high volume levels for long periods can lead to permanent hearing defects. Please protect your hearing, Sennheiser headphones have an excellent sound quality even at low volumes.

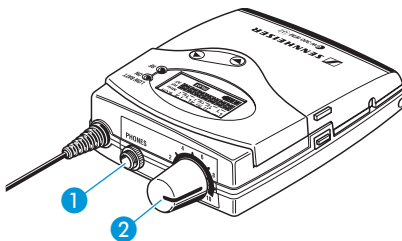

# Using the components

## Switching the components on/off

### Switching the transmitter on/off

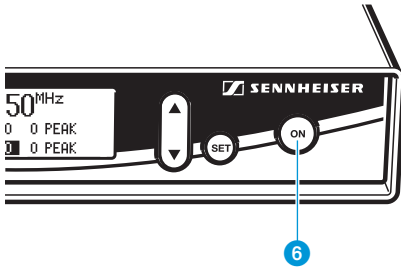

- ▶ Press the **ON** button **6** to switch the transmitter on.
- ▶ To switch the transmitter off, press the **ON** button until "OFF" appears on the display.

#### Note:

The transmitter can only be switched off when the standard display is shown on the display panel. Within the operating menu, the **ON** button serves as the ESC (cancel) key, i.e. you cancel your entry and return to the standard display.

### Switching the receiver on/off

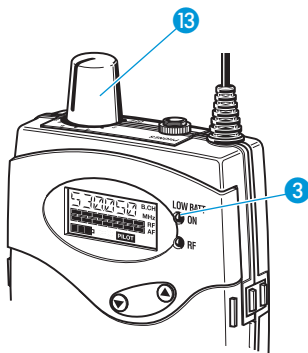

- ▶ To switch the receiver on, turn the volume control **13** clockwise until it clicks. The red LED **3** lights up.
- ▶ To switch the receiver off, turn the volume control **13** counterclockwise until it clicks. The red LED **3** goes off.

#### Note:

- The receiver has a short switch-on delay.
- Remove the batteries or the accupack when the receiver will not be used for extended periods of time.

## Adjusting the volume

You can adjust the volume at the headphone output on both the transmitter and the receiver.

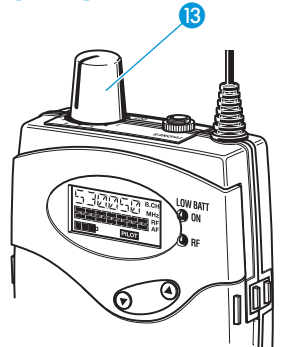
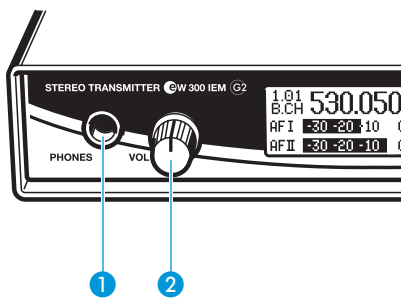

- ▶ Use the volume control **2** or **13** to adjust the volume of the connected headphones.

#### Volume up? – NO!

When people use headphones, they tend to choose a higher volume than with loudspeakers. Listening at high volume levels for long periods can lead to permanent hearing defects. Please protect your hearing, Sennheiser headphones have an excellent sound quality even at low volumes.

## Adjusting the balance

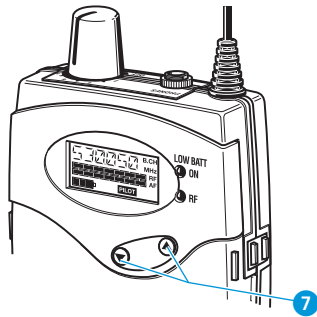

During stereo operation – and provided that the standard display is shown on the display panel – the ▼/▲ rocker button 7 serves to adjust the balance between the left and right stereo signal.

During FOCUS operation, the ▼/▲ rocker button 7 serves to adjust the relative levels of the two separate channels in the mixed mono signal (see “Stereo/FOCUS selection (receiver only)” on page 64).

## Activating/deactivating the lock mode

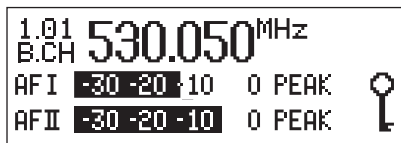

SR 300 IEM G2

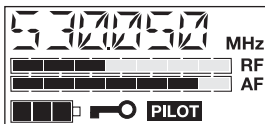

EK 300 IEM G2

Transmitter and receiver have a lock mode that can be activated or deactivated via the operating menu (see “Activating/deactivating the lock mode” on page 67). The lock mode prevents that

- the transmitter is accidentally programmed or switched off during operation
- the balance setting is accidentally changed via the receiver's ▼/▲ rocker button.

## Attaching the receiver to clothing

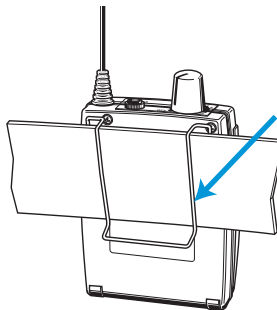

The receiver is attached to clothing (e.g. belt, waistband) with the supplied belt clip.

# The operating menu

To ensure intuitive operation of both transmitter and receiver, the operating menus have been largely standardized. As a result, adjustments to the settings can be made quickly and “without looking” – even in stressful situations, for example on stage or during a live show or presentation.

## The buttons

Buttons	Mode	To ...
ON (transmitter only)	Standard display	switch the transmitter on and off
	Operating menu	cancel the entry and return to the standard display
	Setting mode	cancel the entry and return to the standard display
SET	Standard display	get into the operating menu
	Operating menu	get into the setting mode of the selected menu
	Setting mode	store the settings and return to the top menu level
▲/▼	Standard display	without function (transmitter) adjust the balance (receiver)
	Operating menu	change to the previous menu (▲) or change to the next menu (▼)
	Setting mode	adjust the setting of the selected menu: option (▲/▼)
ESC (receiver only)	Standard display	without function
	Operating menu	cancel the entry and return to the standard display
	Setting mode	cancel the entry and return to the standard display



## Overview of menus

Transmitter		Receiver	
Display	Function of the menu	Display	Function of the menu
Bank	Switching between channel banks	BANK	Switching between channel banks
Channel	Switching between the channels in a channel bank	CHAN	Switching between the channels in a channel bank
Tune	Setting a receiving frequency for the channel bank "U" (user bank)	TUNE	Setting a receiving frequency for the channel bank "U" (user bank)
—	—	SCAN	Scanning a channel bank for free channels
—	—	SQELCH	Adjusting the squelch threshold
—	—	ST-FOC	Stereo/FOCUS selection
—	—	LTD	Limiting the volume at the headphone output
—	—	Hi-BST	Activating/deactivating the frequency boost
Sensitiv	Adjusting the sensitivity	—	—
Display	Selecting the standard display	DISPLY	Selecting the standard display
Name	Entering a name	NAME	Entering a name
Reset	Loading the factory-preset default settings	RESET	Loading the factory-preset default settings
—	—	PILOT	Activating/deactivating the pilot tone evaluation
LCD Contr	Adjusting the contrast of the graphic display	—	—
Mode	Stereo/Mono selection	—	—
Lock	Activating/deactivating the lock mode	LOCK	Activating/deactivating the lock mode
Exit	Exiting the operating menu and returning to the standard display	EXIT	Exiting the operating menu and returning to the standard display

## Working with the operating menu

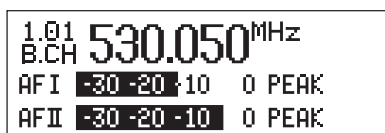

SR 300 IEM G2

By way of example of the "Tune" menu, this section describes how to use the operating menu.

After switching the unit on, the standard display is shown on the display panel.

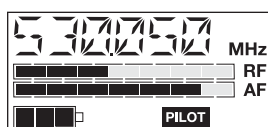

EK 300 IEM G2

Menu	
Channel	01
Tune	786.300MHz
Scan	

TUNE

### Getting into the operating menu

- ▶ Press the **SET** button to get from the standard display into the operating menu.

The last menu selected flashes on the display. With the transmitter, the current setting is additionally displayed.

Tune	
U.01	786.300 MHz
B.CH	

803.50 MHz

### Selecting a menu

- ▶ Press the **▲/▼** buttons to select a menu.
- ▶ Press the **SET** button to get into the setting mode of the selected menu. With the receiver, the current setting that can be adjusted flashes on the display. With the transmitter, the name of the menu and the current setting are displayed.

Tune	
U.01	786.425 MHz
B.CH	

812.575 MHz

### Adjusting a setting

- ▶ Press the **▲/▼** buttons to adjust the setting. By briefly pressing the **▲/▼** buttons, the display jumps either forwards or backwards to the next setting. In the "Channel", "Tune" and "Name" menu, the **▲/▼** buttons feature a "fast search" function. If you hold down a button, the display cycles continuously. The "fast search" function allows you to get fast and easily to your desired setting. With the receiver, the new setting flashes on the display until it is stored.

Stored

STORE II

### Storing a setting

- ▶ Press the **SET** button to store the setting. "Stored" appears on the display, indicating that the setting has been stored. The display then returns to the top menu level.

With most menus, new settings become effective immediately without having to be stored. An exception are the "Bank", "Channel", "Tune" and "Reset" menus of the transmitter and the "RESET" menu of the receiver. With these menus, new settings only become effective after they have been stored ("Stored" appears on the display, indicating that the setting has been stored).

Menu	
Lock	
Exit	
Bank	1

EXIT

### Exiting the operating menu

- ▶ Select the "Exit" menu to exit the operating menu and to return to the standard display.

When you have entered the operating menu, the transmitter's **ON** button serves as the ESC (cancel) key, i.e. by briefly pressing this button, you cancel your entry and return to the standard display. The receiver has a separate **ESC** button with which you can cancel your entry.

# Operating menu of the stereo transmitter

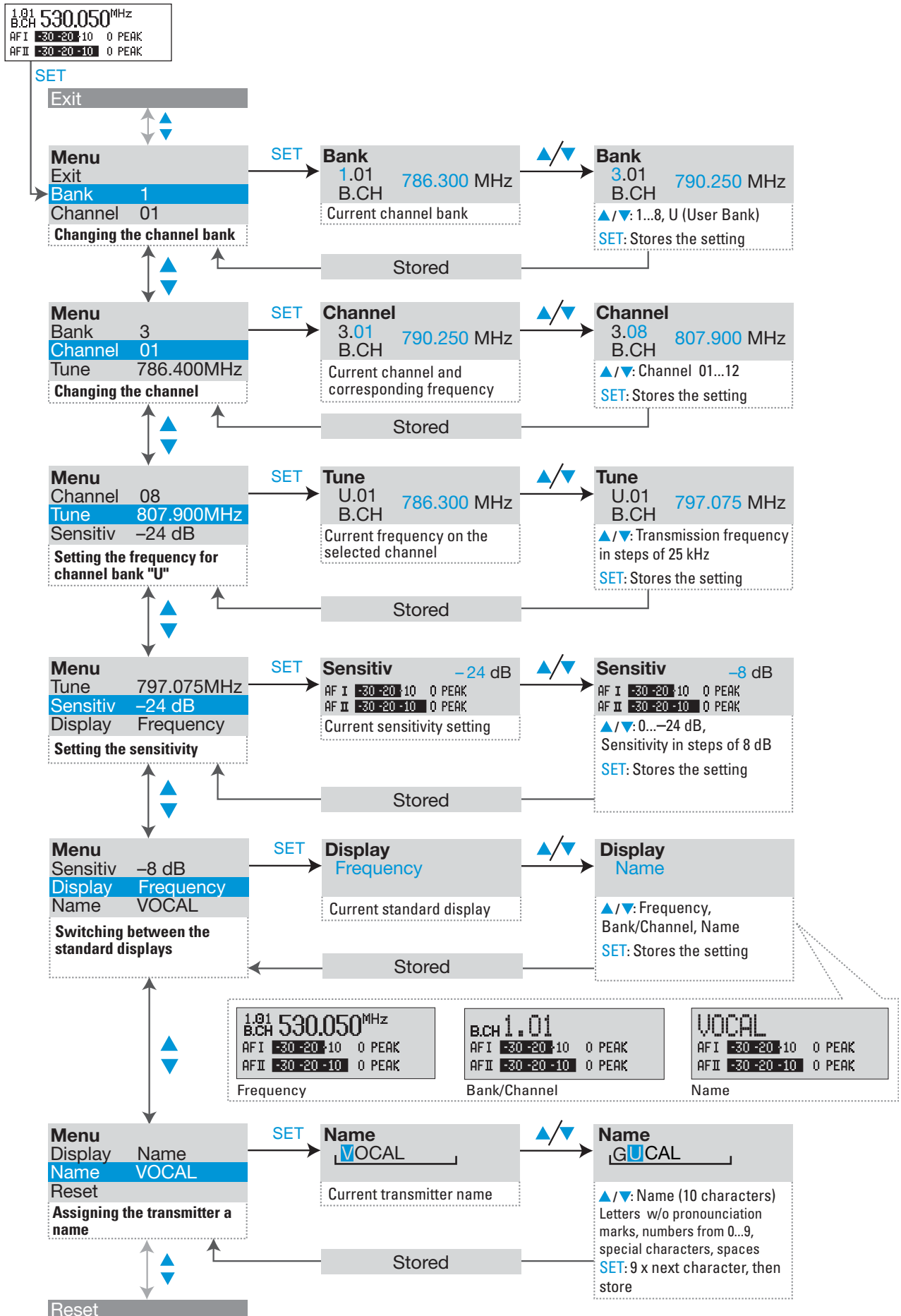

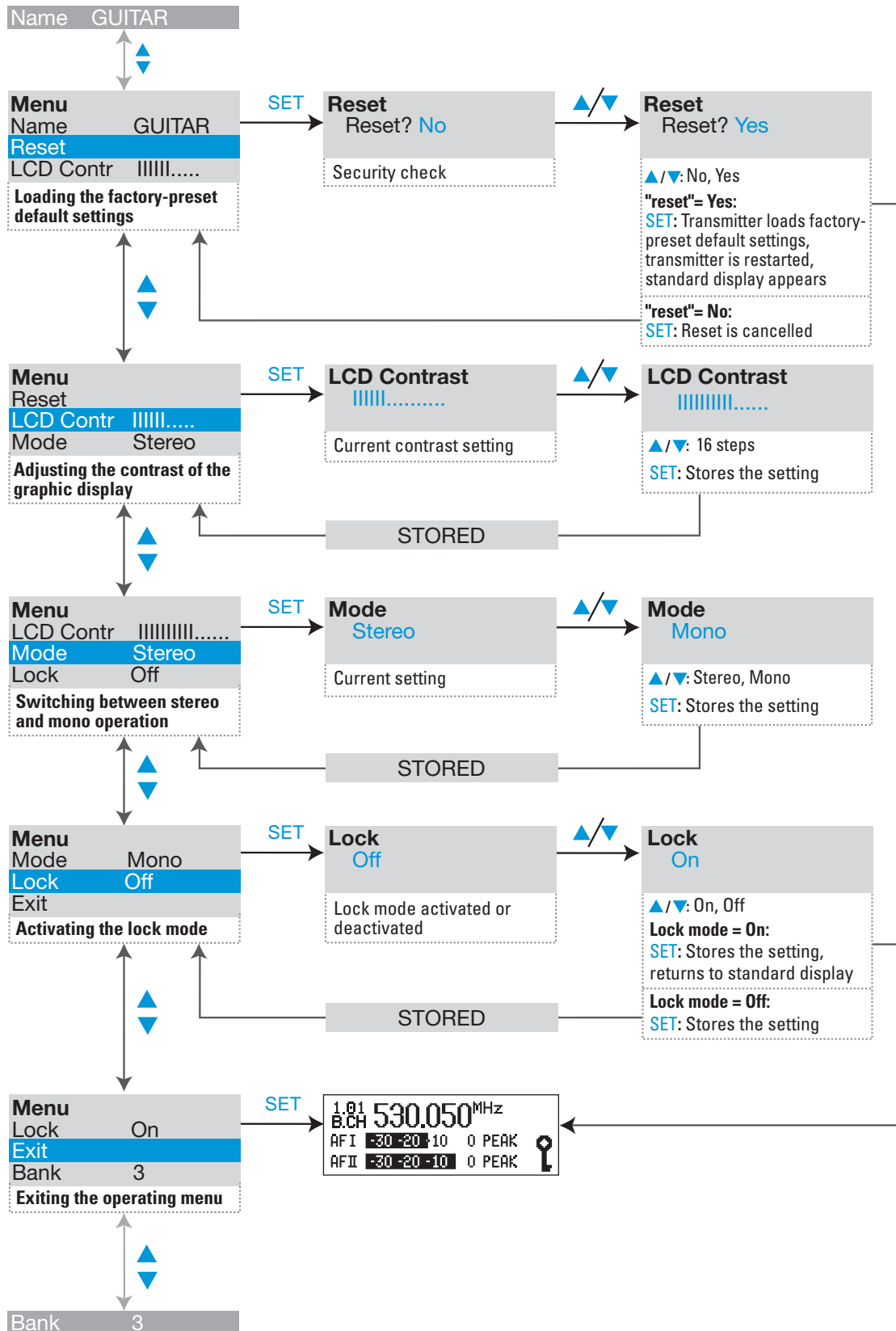

# Operating menu of the stereo receiver

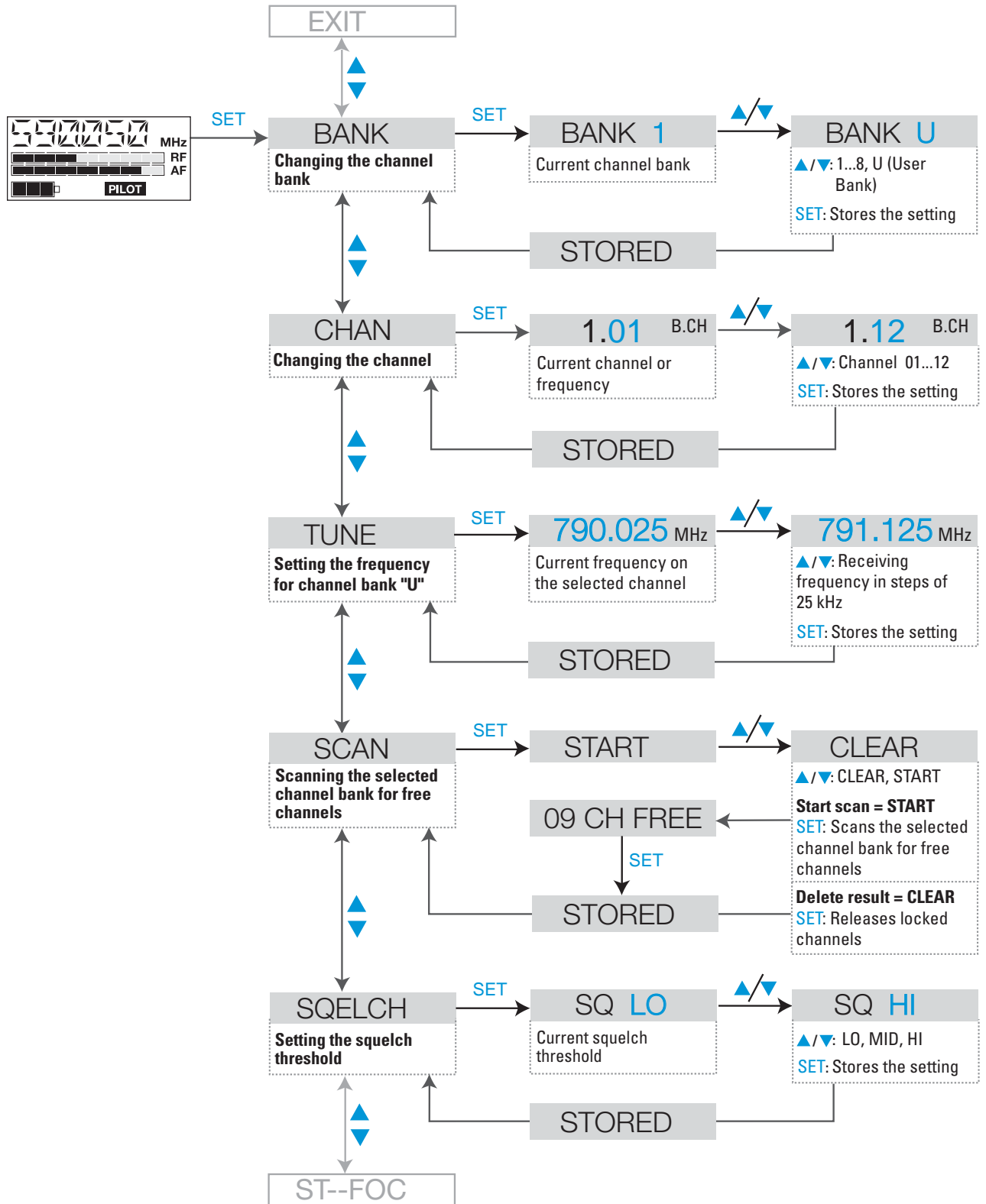



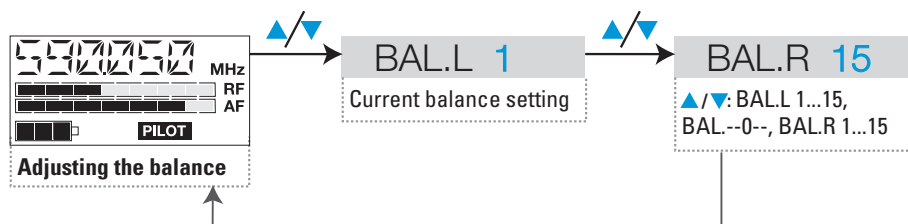
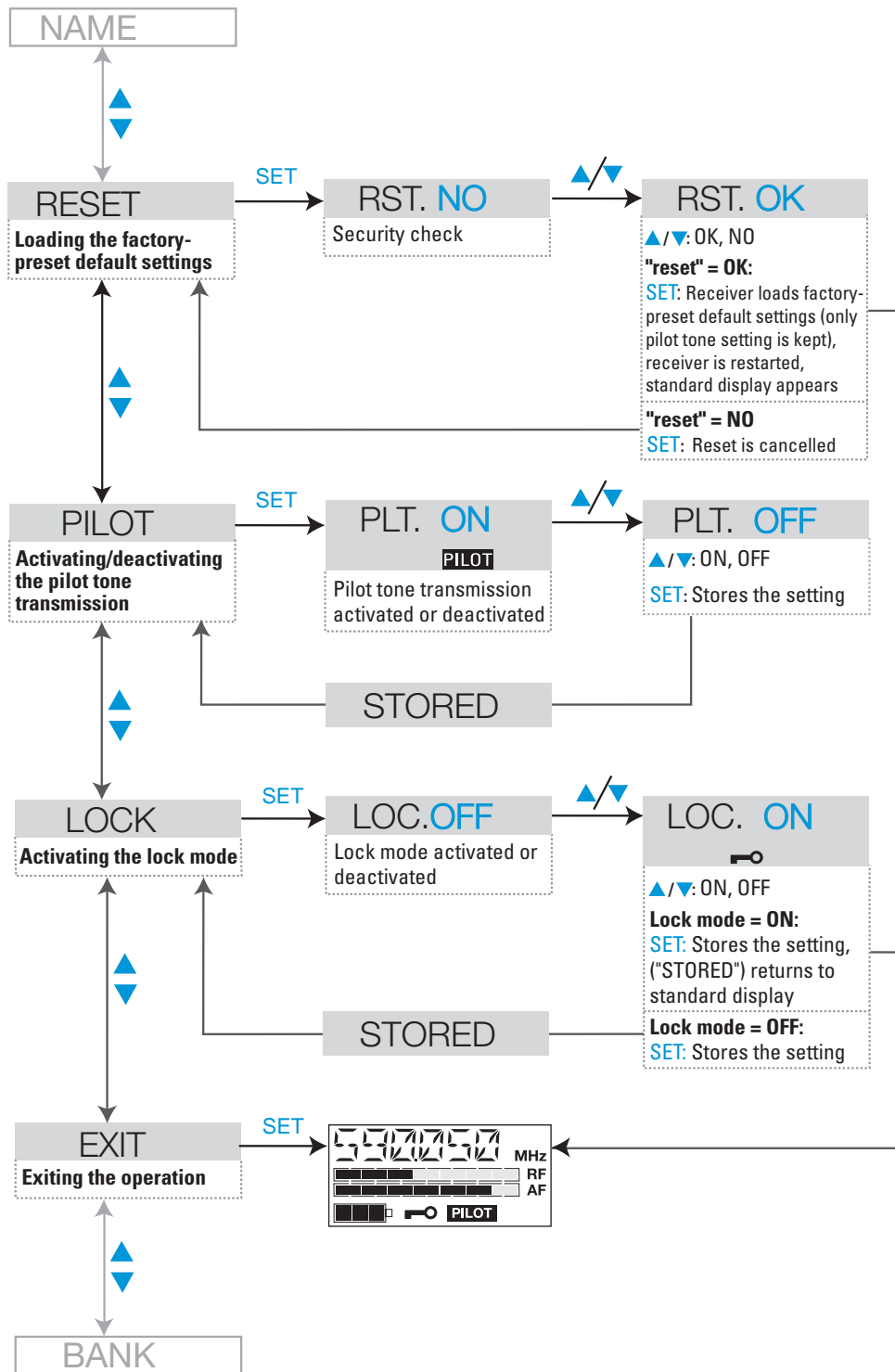

# Adjustment tips for the operating menu

## Switching between channel banks

### BANK Bank

Via the “Bank” menu, you can switch between the nine channel banks of the ew 300 IEM G2 transmitter and receiver. The channel banks “1” to “8” have up to 12 switchable channels that are factory-preset to a transmission/receiving frequency (see “The channel bank system” on page 42). The channel bank “U” (user bank) also has up to 12 switchable channels to store your selection out of 1440 transmission/receiving frequencies that are freely selectable within the preset frequency range.

When switching from one channel bank to another, the channel with the lowest channel number is automatically displayed. If, during the last scan of this channel bank, an interfering frequency was detected on the channel with the lowest channel number, the receiver display panel automatically displays the next free channel (see below).

## Switching between the channels in a channel bank

### CHAN Channel

Via the “Channel” menu, you can switch between the channels in a channel bank.

Always set the transmitter and the receiver of a transmission link to the same channel. After scanning a channel bank (see “Scanning the channel banks for free channels (receiver only)” on page 62), only the free channels are displayed. Set the transmitter to one of the free channels

## Selecting the frequencies to be stored in the channel bank “U”

### TUNE Tune

Via the “Tune” menu, you can select the frequencies to be stored in the channel bank “U” (user bank).

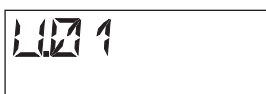

When you have selected one of the channel banks “1” to “8” and then select the “Tune” menu, the transmitter or receiver automatically switches to channel 01 of the channel bank “U”. In this case, “U.01” briefly appears on the display.

- ▶ Use the ▲/▼ buttons to select the desired transmission or receiving frequency. Transmission and receiving frequencies are tunable in 25-kHz steps within a switching bandwidth of 36 MHz max. For intermodulation-free frequencies, please refer to the enclosed frequency table.

## Scanning the channel banks for free channels (receiver only)

### SCAN

Before putting one or several transmission links into operation, you should scan the selected channel bank for free channels.



### Starting the scan and storing the scan result

- ▶ Before starting the scan, switch all transmitters of your system off, since channels used by switched-on transmitters will not be displayed as “free channels”.
- ▶ Select the “SCAN” menu.
- ▶ Select “START” and confirm your selection by pressing the SET button. After the scan is completed, the number of free channels is displayed. Pressing the SET button once more will store the scan result and lock all channels that are used or subject to interference.

### Releasing locked channels

- ▶ Select the “SCAN” menu.
- ▶ Select “CLEAR” and confirm your selection by pressing the SET button. All channels in this channel bank can now be selected again.

## Multi-channel operation

For multi-channel operation, only use the free channels in a channel bank.

Before putting the transmission links into operation, we recommend performing an auto scan.

- ▶ Select a channel bank on a receiver.
- ▶ Scan this channel bank for free channels. If not enough free channels are available in the selected channel bank, repeat the scan with another channel bank.
- ▶ Apply the scan result to all other transmitters and receivers.

## Adjusting the squelch threshold (receiver only)

### SQUELCH

The receiver is equipped with a squelch that can be adjusted via the “SQUELCH” menu. The squelch eliminates annoying noise when the transmitter is switched off. It also suppresses sudden noise when there is no longer sufficient transmitter power received by the receiver.

#### Note:

Before adjusting the squelch threshold to a different setting, use the volume control 13 to set the volume for the connected headphones to the minimum.

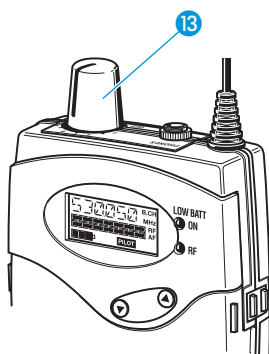

There are three possible squelch settings:

- LO = low
- MID = middle
- HI = high

Selecting the setting “LO” reduces the squelch threshold, selecting the setting “HI” increases the squelch threshold. Adjust the squelch threshold – with the transmitter switched off – to the lowest possible setting that suppresses hissing noise.

## IMPORTANT!

### Notes:

- If the squelch threshold is adjusted too high, the transmission range will be reduced. Therefore, always adjust the squelch threshold to the lowest possible setting.
- When in the setting mode of the "SQELCH" menu, pressing the ▼ button for more than three seconds will switch the squelch off. "SQ.OFF" appears on the display. If no RF signal is being received, hissing noise will occur. This setting is for test purposes only.

## Stereo/FOCUS selection (receiver only)

### ST-FOC

Via the "ST-FOC" menu, you can switch between stereo and FOCUS operation.

In both operating modes, the SR 300 IEM G2 stereo transmitter has to be set to stereo operation.

When the receiver is set to stereo operation, the left-right signals are available as usual.

When the receiver is set to FOCUS operation, the left-right signals are mixed and are available as a mono signal in both headphone channels. Use the ▼/▲ rocker button to adjust the relative levels of the two separate channels in the mixed mono signal (see "Adjusting the balance" on page 53).

## Limiting the volume at the headphone output (receiver only)

### LTD

Via the "LTD" menu, you can switch the limiter on and off. With the limiter switched on, the volume at the headphone output will be reduced.

## Activating/deactivating the frequency boost (receiver only)

### HI-BST

Via the "HI-BST" menu, you can boost the AF frequency response at 10 kHz. As a result, headphones with magnetic transducers sound better.

## Adjusting the sensitivity (transmitter only)

### Sensitiv

To match the transmitter to the output level of the connected unit (e.g. mixing console), you can adjust the input sensitivity in four steps of 8 dB via the "Sensitiv" menu.

The input sensitivity is adjusted too high when close talking distances, speakers with loud voices or loud music passages cause overmodulation in the transmission link. In this case, the transmitter's "PEAK" warning will light up and the receiver's level display for audio signal "AF" will show full deflection.

If, on the other hand, the sensitivity is adjusted too low, the transmission link will be undermodulated, which would result in a signal with high background noise.

The sensitivity is correctly adjusted when the level display for audio signal "AF" shows full deflection only during the loudest passages.

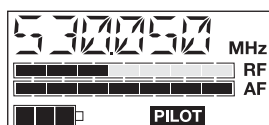
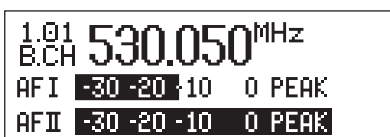

## DISPLY Display

### Selecting the standard display

Via the "Display" menu, you can select the standard display.

#### SR 300 IEM G2 stereo transmitter

Selectable standard display	Contents of standard display
"Frequency" (display of the frequency)	
"Bank/Channel" (display of the channel bank and channel number)	
"Name" (display of the freely selectable name)	

#### EK 300 IEM stereo receiver

Selectable standard display	Contents of standard display
"FREQ"	
"NAME"	
"CHAN"	

### Entering a name

## NAME Name

Via the "Name" menu, you can enter a freely selectable name for the transmitter and the receiver. You can, for example, enter the name of the performer for whom the adjustments have been made.

The name can be displayed on the standard display and can consist of up to ten characters (transmitter) and up to six characters (receiver) such as:

- letters (without pronunciation marks),
- numbers from 0 to 9,
- special characters e.g. ( ) - . \_ and spaces.

To enter a name, proceed as follows:

- ▶ Press the **SET** button to get into the setting mode of the "Name" menu. The first segment starts flashing on the display.
- ▶ With the **▲/▼** buttons you can now select a character. By briefly pressing

a button, the display jumps either forwards or backwards to the next character. If you hold down a button, the display starts cycling continuously.

- ▶ Press the **SET** button to change to the next segment and select the next character.
- ▶ Have you entered the name completely? Press the **SET** button to store your setting and to return to the previous menu level.

## Loading the factory-preset default settings

### RESET Reset

Via the “Reset” menu, you can load the factory-preset default settings. With the receiver, however, the selected setting for the pilot tone remains unchanged. After the reset, the unit is restarted and the standard display is shown on the display panel.

## Activating/deactivating the pilot tone evaluation (receiver only)

### PILOT Pilot

Via the “Pilot” menu, you can activate or deactivate the pilot tone evaluation of the receiver. The pilot tone is used

- to code the transmitter’s stereo signal,
- to support the squelch function (Squelch).

During stereo operation, the transmitter adds the pilot tone to the transmitted stereo signal and the receiver detects and evaluates the pilot tone. When the transmitter is set to mono operation, deactivate the pilot tone evaluation on the receiver.

You can combine units of first and second generation ew 300 IEM systems without any problems.

## Adjusting the contrast of the graphic display (transmitter only)

### LCD-Contr

Via the “LCD Contr” menu, you can adjust the contrast of the graphic display in 16 steps.

## Stereo/Mono selection (transmitter only)

### Mode

Via the “Mode” menu, you can switch the transmitter between mono and stereo operation.

#### Note:

Connect any unit that only delivers a mono signal to the transmitter’s left XLR-3F socket 9 and set the transmitter to mono operation. The receiver automatically “identifies” the transmitted audio signal and does not need to be set to mono operation. However, you have to deactivate the pilot tone evaluation on the receiver.

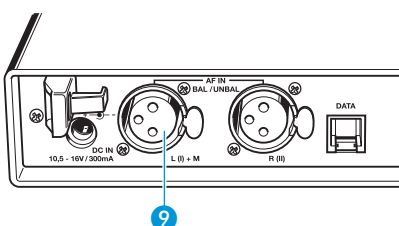

## Activating/deactivating the lock mode

### LOCK Lock

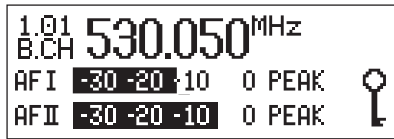

SR 300 IEM G2

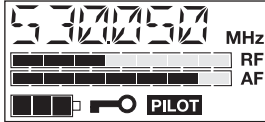

EK 300 IEM G2

Via the "Lock" menu, you can activate or deactivate the lock mode.

The lock mode icon on the display indicates that the lock mode is activated.

To deactivate the lock mode, first press the **SET** button. Then press the **▲/▼** buttons to select "Lock Off". If you confirm your selection by pressing the **SET** button, the buttons can be operated as usual.

## Exiting the operating menu

### EXIT Exit

Via the "Exit" menu, you can exit the operating menu and return to the standard display.

# Troubleshooting

## Error checklist

Problem	Possible cause	Possible solution
No operation indication	Batteries are flat or accupack is flat (receiver only)	Replace the batteries or recharge the accupack
	No mains connection (transmitter only)	Check the connections of the mains unit
No RF signal	Transmitter and receiver are not on the same channel	Set transmitter and receiver to the same channel
	Transmitter is out of range	Check the squelch threshold setting (see "Adjusting the squelch threshold (receiver only)" on page 63) or reduce the distance between transmitter and receiving antenna
RF signal available, no audio signal, "MUTE" display appears on the display panel	Transmitter is set to mono operation and the pilot tone evaluation of the receiver is activated	Deactivate the pilot tone evaluation on the receiver
	Receiver's squelch threshold is adjusted too high	See "Adjusting the squelch threshold (receiver only)" on page 63)
Audio signal has a high level of background noise	Transmitter sensitivity is adjusted too low	See "Adjusting the sensitivity (transmitter only)" on page 64
Audio signal is distorted	Transmitter sensitivity is adjusted too high	See "Adjusting the sensitivity (transmitter only)" on page 64
No access to a certain channel	During scanning, an RF signal has been detected on this channel and the channel has been locked	See "Scanning the channel banks for free channels (receiver only)" on page 62

If problems occur that are not listed in the above table or if the problems cannot be solved with the proposed solutions, please contact your local Sennheiser agent for assistance.

## Recommendations and tips

### ... for the EK 300 IEM G2 receiver

- The antenna of the EK 300 IEM G2 should hang freely and be at least 1 cm away from the body. The antenna must not be in direct contact with the skin.

### ... for optimum reception

- Transmission range depends to a large extent on location and can vary from about 10 m to about 150 m. There should be a "free line of sight" between transmitting and receiving antennas.
- If, with the SR 300 IEM G2 transmitter, transmission conditions are unfavourable, you should use a remote antenna which is connected via antenna cable.
- To avoid overmodulating the receiver, observe a minimum distance of 5 m between transmitting and receiving antennas.
- Observe a minimum distance of 50 cm between transmitting antennas and metal objects (such as cross members or reinforced-concrete walls).

### ... for multi-channel operation

- For multi-channel operation, you can only use the channels in a channel bank. Each of the channel banks "1" to "8" accommodates up to 12 factory-preset frequencies which are intermodulation-free. For alternative frequency combinations, please refer to the enclosed frequency table. The freely selectable frequencies can be selected via the "Tune" menu and can be stored in the channel bank "U".
- When using several transmitters simultaneously, interference can be avoided by maintaining a minimum distance of 20 cm between two transmitters. For multi-channel applications, use the AC 2 transmitter combiner (see "Accessories" on page 73).

## Care and maintenance

Use a slightly damp cloth to clean the units from time to time.

### Note:

Do not use any cleansing agents or solvents.

# Additional information

## HDX noise reduction

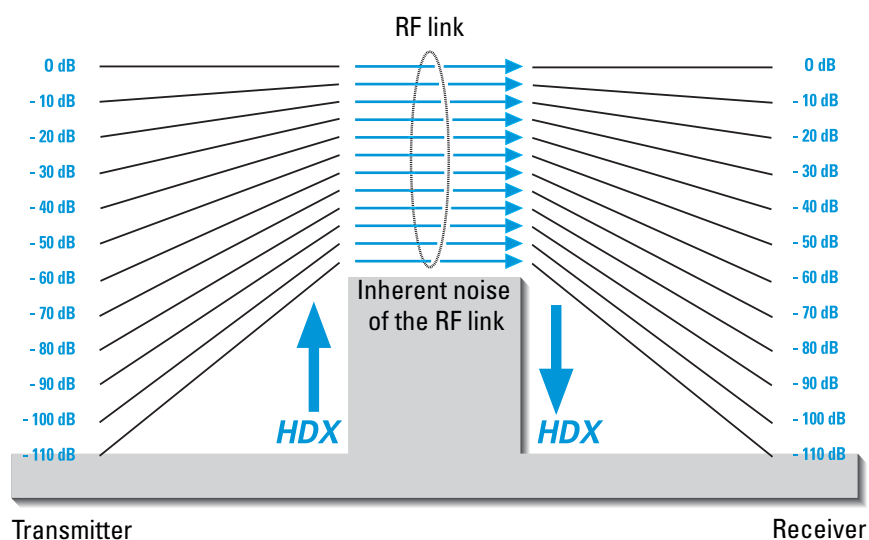

The evolution wireless G2 series is equipped with **HDX**, the Sennheiser noise reduction system that reduces RF interference. It increases the signal-to-noise ratio in wireless audio transmission to more than 110 dB.

**HDX** is a wideband compander system which compresses the audio signal in the transmitter in a 2:1 ratio (related to dB) to lift it above the inherent noise floor of the RF link. In the receiver the signal is expanded in an identical and opposite way in a 1:2 ratio to restore the original signal, at the same time reducing the RF noise to below the noise floor of the receiver.

**HDX** has been specially developed for high quality radiomicrophone systems.

### Note:

Only transmitters and receivers that are equipped with **HDX** can work correctly with each other. If non **HDX** equipment was mixed with **HDX**, the dynamic range would be drastically reduced and the transmission would sound blunt and flat. **HDX** is permanently active and cannot be switched off.

## Wireless transmission systems

With the ew 300 IEM G2 system, Sennheiser puts an end to cable tangles and enables complete freedom of movement. The systems operate exclusively in the UHF band. UHF transmission is extremely reliable and is far less prone to interference than the overcrowded VHF band – harmonics from mains units, fluorescent tubes, refrigerators, computers, etc. are virtually eliminated. Also indoor propagation of UHF radio waves is better than VHF so that the RF power can be kept low – this is also an advantage when using multi-channel systems. Finally, UHF frequency ranges are being approved all over the world for radiomicrophone usage – in some countries licence-free.

Correct adjustment of transmitter sensitivity is vital. Too high and you get overmodulation and distortion, too low and you get undermodulation and a noisy signal. Please set the sensitivity correctly for the microphone/usage and check it before every performance to ensure best operation.



## Squelch

### Pilot tone squelch

When the transmitter is set to stereo operation, it adds a 19-kHz pilot tone to the audio signal. The receiver checks incoming audio signals to see if the pilot tone is present. In the absence of the 19-kHz signal, the receiver's audio output will remain muted, even if a strong RF signal is present.

This prevents strong interfering signals from causing hissing noise in the receiver when the transmitter is switched off.

### Field strength-dependent squelch

Depending on the strength of the received RF signal, the receiver's audio output is opened or muted. Via the "SQELCH" menu of the receiver, the squelch threshold can be adjusted in three steps (LO, MID, HI).

# Specifications

## System

### RF characteristics

Modulation	wideband FM stereo, MPX pilot tone
Frequency ranges	518–554, 626–662, 740–776, 786–822, 830–866 MHz
Transmission/receiving frequencies	8 channel banks with up to 12 factory-preset channels each 1 channel bank with up to 12 freely selectable channels (1440 frequencies, tunable in steps of 25 kHz)
Switching bandwidth	36 MHz
Nominal/peak deviation	$\pm 24$ kHz/ $\pm 48$ kHz
Frequency stability	$\leq \pm 15$ ppm

### AF characteristics

Noise reduction system	Sennheiser HDX
AF frequency response	40–15,000 Hz
MPX pilot tone (Frequenz/Hub)	19 KHz/ $\pm 4$ kHz
S/N ratio (at 1 mV and peak deviation)	$\geq 91$ dB(A)
THD (at nominal deviation and 1 kHz)	$\leq 0.9$ %

### General data

Temperature range	$-10$ °C to $+55$ °C
Dimensions of carrying case [mm]	380 x 370 x 70
Weight of carrying case	approx. 3000 g

## IE 3 in-ear headphones

Frequency response	40–20,000 Hz
Max. SPL	118 dB SPL
Impedance	32 $\Omega$

## EK 300 IEM G2 stereo receiver

### RF characteristics

Receiver principle	non diversity
Sensitivity (with HDX, peak deviation)	$< 2.5$ $\mu$ V at 52 dBA <sub>rms</sub> S/N ratio
Adjacent channel rejection	$\geq 70$ dB
Intermodulation attenuation	$\geq 70$ dB
Blocking	$\geq 80$ dB
Squelch	4 steps: OFF LO: 5 dB $\mu$ V MID: 15 dB $\mu$ V HI: 25 dB $\mu$ V
Pilot tone squelch (MPX pilot tone)	can be switched off

### AF characteristics

Headphone output	3.5 mm jack socket
AF output voltage (at peak deviation 1 kHz <sub>AF</sub> ) PHONES	2 x $\geq 100$ mW at 32 $\Omega$

### Overall device

Power supply	2 AA size batteries, 1.5 V
Nominal voltage	2.4 V
Max. power consumption at nominal voltage	approx. 190 mA (2 x 30 mW)
Power consumption with switched-off receiver	$\leq 250$ $\mu$ A
Operating time (with batteries)	6–10 h (depending on volume level)
Operating time (with BA 2015 accupack)	6–10 h (depending on volume level)
Dimensions [mm]	82 x 64 x 24
Weight (incl. batteries)	approx. 170 g

## SR 300 IEM G2 stereo transmitter

### RF characteristics

RF output power at 50 Ω  
Antenna output

≥ 20 mW, internally adjustable to 10 mW  
BNC socket, 50 Ω

### AF characteristics

Headphone output  
Output power at headphone output  
AF input  
Max. input voltage (at peak deviation, 1 kHz)  
Input impedance

1/4" (6.3 mm) stereo jack socket  
≥ 100 mW at 32 Ω (2x)  
2 x XLR-3 socket, balanced  
+10dB<sub>u</sub>  
10 kΩ

### Overall device

Power supply  
Nominal voltage  
Max. power consumption at nominal voltage  
Dimensions [mm]  
Weight

10.5–16 V DC  
12 V DC  
approx. 300 mA  
212 x 145 x 38  
approx. 1100 g

## Connector assignment

SR 300 IEM G2:

1/4" (6.3 mm) stereo jack plug  
for headphone output

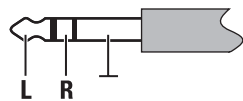

SR 300 IEM G2:

XLR-3M connector

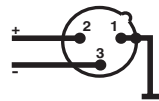

SR 300 IEM G2:

DC connector for power  
supply



EK 300 IEM G2:

3.5 mm stereo jack plug for  
headphone output

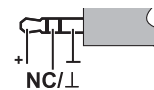

## Accessories

- GA 2** 19" rack adapter
- AM 2** Antenna mount for mounting antennas to the front of the GA 2
- A 1031-U** UHF antenna,  
passive, omni-directional, can be mounted onto a stand
- A 2003-UHF** UHF antenna,  
passive, directional, can be mounted onto a stand
- GZL 1019-A1** Antenna cable with BNC connectors 1 m
- GZL 1019-A5** Antenna cable with BNC connectors 5 m
- AC 2** Transmitter combiner,  
for combining the RF signals of up to four transmitters onto a single antenna  
and for powering up to four transmitters
- NT 3** Plug-in mains unit for AC 2
- IE 3** In-ear headphones
- IES 3** 1 pair of ear-moulds
- BA 2015** Accupack
- L 2015** Charger for BA 2015 accupack
- CC 2** Carrying case for ew 300 IEM G2 system

## DEUTSCH

Wir übernehmen für das von Ihnen gekaufte Produkt eine Garantie von 24 Monaten. Ausgenommen hiervon sind dem Produkt beigelegte Zubehörartikel, Akkus und Batterien; denn diese Produkte haben wegen ihrer Beschaffenheit eine kürzere Lebensdauer, die zudem im Einzelfall konkret von Ihrer Nutzungsintensität abhängt.

Die Garantiezeit beginnt ab Kaufdatum. Zum Nachweis heben Sie bitte unbedingt den Kaufbeleg auf. Ohne diese Nachweise, die der zuständige Sennheiser-Service-Partner prüft, werden Reparaturen grundsätzlich kostenpflichtig ausgeführt.

Die Garantieleistungen bestehen nach unserer Wahl in der unentgeltlichen Beseitigung von Material- oder Herstellungsfehlern durch Reparatur, Tausch von Teilen oder des kompletten Geräts. Von der Garantie ausgenommen sind Mängel durch unsachgemäßen Gebrauch (z.B. Bedienungsfehler, mechanische Beschädigungen, falsche Betriebsspannung), Verschleiß, aufgrund höherer Gewalt und solche Mängel, die Ihnen beim Kauf bereits bekannt sind. Der Garantieanspruch erlischt bei Eingriffen in das Produkt durch nicht autorisierte Personen oder Werkstätten.

Im Garantiefall senden Sie das Gerät inklusive Zubehör und Kaufbeleg an den für Sie zuständigen Service-Partner. Zur Vermeidung von Transportschäden sollte möglichst die Original-Verpackung verwendet werden.

Ihre gesetzlichen Mängelansprüche aus dem Kaufvertrag gegen den Verkäufer werden durch diese Garantie nicht eingeschränkt. Die Garantie kann weltweit in allen Ländern – außer in den USA – in Anspruch genommen werden, in denen das jeweils nationale Recht unseren Garantiebestimmungen nicht entgegensteht

## ENGLISH

The guarantee period for this Sennheiser product is 24 months from the date of purchase. Excluded are accessory items, rechargeable or disposable batteries that are delivered with the product; due to their characteristics these products have a shorter service life that is principally dependent on the individual frequency of use.

The guarantee period starts from the date of original purchase. For this reason, we recommend that the sales receipt be retained as proof of purchase. Without this proof (which is checked by the responsible Sennheiser service partner) you will not be reimbursed for any repairs that are carried out.

Depending on our choice, guarantee service comprises, free of charge, the removal of material and manufacturing defects through repair or replacement of either individual parts or the entire device. Inappropriate usage (e.g. operating faults, mechanical damages, incorrect operating voltage), wear and tear, force majeure and defects which were known at the time of purchase are excluded from guarantee claims. The guarantee is void if the product is manipulated by non-authorized persons or repair stations.

In the case of a claim under the terms of this guarantee, send the device, including accessories and sales receipt, to the responsible service partner. To minimise the risk of transport damage, we recommend that the original packaging is used. Your legal rights against the seller, resulting from the contract of sale, are not affected by this guarantee.

The guarantee can be claimed in all countries outside the U.S. provided that no national law limits our terms of guarantee.

## FRANÇAIS

La période de garantie pour ce produit Sennheiser est de 24 mois à compter de la date d'achat. Sont exclues, les batteries rechargeables ou jetables livrées avec le produit. En raison de leurs caractéristiques ces produits ont une durée de vie plus courte liée principalement à la fréquence d'utilisation.

La période de garantie commence à la date de l'achat. Pour cette raison, nous vous recommandons de conserver votre facture comme preuve d'achat. Sans cette preuve -qui est vérifiée par Sennheiser -aucune prise en compte de la garantie ne pourra être retenue.

La garantie comprend, gratuitement, la remise en état de fonctionnement du matériel par la réparation ou le remplacement des pièces défectueuses ou dans le cas où la réparation n'est pas possible, par échange du matériel. L'utilisation inadéquate (mauvaise utilisation, dégâts mécaniques, tension électrique incorrecte), sont exclus de la garantie. La garantie est invalidée en cas d'intervention par des personnes non-autorisées ou des stations de réparation non agréées.

Pour faire jouer la garantie, retournez l'appareil et ses accessoires, accompagnés de la facture d'achat, à votre distributeur agréé. Pour éviter des dégâts durant le transport il est recommandé d'utiliser l'emballage d'origine.

Votre droit légal de recours contre le vendeur n'est pas limité par cette garantie. La garantie peut être revendiquée dans tous les pays à l'extérieur des Etats-Unis à condition qu'aucune loi nationale n'en invalide les termes.

## ITALIANO

La Sennheiser garantisce il prodotto da voi acquistato per una durata di 24 mesi. Sono esclusi da questa garanzia gli accessori in dotazione con il prodotto, gli accumulatori e le batterie perché questi prodotti hanno un ciclo di vita più breve che dipende molto dall'intensità d'utilizzo. Il periodo di garanzia decorre dalla data dell'acquisto. Fa fede il documento d'acquisto valido agli effetti fiscali che deve essere conservato. Senza questo documento, che deve essere controllato dal centro di servizio Sennheiser, qualsiasi riparazione viene effettuata solo dietro pagamento.

Le prestazioni gratuite di garanzia possono consistere nell'eliminazione del difetto di materiale o fabbricazione attraverso la riparazione, la sostituzione di parti o del completo apparecchio, secondo nostro insindacabile giudizio. Sono esclusi dalla garanzia i guasti derivanti da cattivo uso dell'apparecchio (p.e. mancata osservanza delle istruzioni all'uso, danneggiamenti meccanici, tensione d'alimentazione errata), dall'usura, da cause di forza maggiore o da malfunzionamenti già a vostra conoscenza al momento dell'acquisto. La garanzia decade inoltre in caso di manomissioni effettuate da persone o centri di manutenzione non autorizzate. In caso di un reclamo nel periodo di garanzia vogliate inviare l'apparecchio insieme agli accessori in dotazione e il documento d'acquisto al vostro centro servizio autorizzato.

Per evitare danni di trasporto consigliamo di utilizzare l'imballo originale. In caso di guasto questa garanzia non pregiudica i vostri diritti derivanti dal contratto d'acquisto verso il negoziante dove è stato acquistato il prodotto.

La garanzia è estesa a tutti i paesi del mondo, tranne agli Stati Uniti, e può essere applicata se la legislazione nazionale lo permette.

## ESPAÑOL

El periodo de garantía para este producto es de 24 meses desde la fecha de compra. Quedan excluidos los accesorios adjuntos al producto, acumuladores y baterías dado que, debido a sus características, la vida útil de dichos productos es mucho más corta y, en determinados casos, depende concretamente de la intensidad de utilización. El periodo de garantía comienza a partir de la fecha de compra. Por eso le recomendamos que guarde el recibo como prueba de compra. Sin dicha prueba, que será verificada por el respectivo concesionario Sennheiser, cualquier reparación que sea necesaria será efectuada contra factura.

Según determine el fabricante, las prestaciones de garantía consistirán en la eliminación gratuita de defectos de materiales o fabricación, por medio de reparación, sustitución de piezas, o bien en la sustitución del aparato completo. La garantía no tendrá validez en caso de defectos ocasionados por un uso inadecuado (tales como manejo incorrecto, daños mecánicos, tensión de servicio equivocada), desgaste, o bien efectos de fuerza mayor, y desperfectos ya detectados en el momento de adquirir el producto. La garantía carecerá de validez si el defecto se debe a modificaciones y reparaciones hechas en el producto por personas o talleres no autorizados.

En caso de reclamación sírvase remitir el aparato incluyendo los accesorios y la factura al concesionario Sennheiser encargado de su zona. A fin de evitar daños durante el transporte se aconseja emplear el envase original. Las pretensiones legales por defectos y emanadas del contrato de compraventa frente al vendedor, no quedan limitadas por esta garantía.

La garantía está disponible en todos los países a excepción de EE.UU., siempre que la legislación nacional aplicable no sea contraria a nuestras determinaciones de garantía.

## NEDERLANDS

Wij hanteren voor onze producten een garantietermijn gedurende een periode van 24 maanden. Uitgezonderd hiervan zijn accessoires, accu's en batterijen die aan het product toegevoegd zijn; op grond van hun leeftijd beschikken deze producten over een kortere levensduur die van geval tot geval van hun gebruiksintensiteit afhangt.

De garantietermijn begint vanaf de aankoopdatum. Daarom dient u de originele aankoopbon goed te bewaren. Zonder dit bewijs, dat door de Sennheiser servicepartner wordt gecontroleerd, worden reparaties in principe tegen kostenvergoeding uitgevoerd.

De garantiEVERGOEDINGEN bestaan naar onze keuze uit het kosteloze verhelpen van materiaal- of fabricagefouten op basis van vervanging (afzonderlijke onderdelen of het complete apparaat) danwel reparatie. De garantie vervalt bij verkeerd gebruik of onachtzaamheid

(bijv. bedieningsfouten, mechanische beschadigingen, onjuiste bedrijfsspanning), slijtage gevallen van force majeure of gebreken welke u reeds bij de aankoop heeft gekend. Het recht op garantie vervalt indien reparaties of wijzigingen zijn uitgevoerd door niet bevoegde personen of werkplaatsen. Indien u aanspraak maakt op garantie dient u het apparaat, inclusief accessoires en aankoopbon, franco aan de bevoegde servicepartner toe te zenden. Om beschadigingen gedurende het transport te voorkomen adviseren wij de originele verpakking te gebruiken.

Uw wettelijke garantiereclames tegenover de verkoper worden door deze garantie niet beperkt. De garantie kan wereldwijd in alle landen buiten de VS worden opgevorderd waarin de geldende nationale wetten niet in tegenstelling zijn met onze garantiEVERGOEDINGEN.

**SENNHEISER electronic GmbH & Co. KG**

Am Labor 1, D-30900 Wedemark

erklären, dass die Produkte / declare that these devices / déclarons que ces appareils  
declaramos que estos aparatos / dichiara che questi apparecchi / verklaren, dat deze toestelen

<b>AC 2</b>	<b>Active Antenna Combiner</b>
<b>SK 100/300/500 G2</b>	<b>Pocket Transmitter</b>
<b>SKM 100/300/500 G2</b>	<b>Transmitter, Hand-held</b>
<b>SKP 100/500 G2</b>	<b>Plug-On-Transmitter</b>
<b>SR 300 G2</b>	<b>Stereo Transmitter</b>

den einschlägigen Anforderungen der EG-Richtlinie 89/336/EEC bzw.  
der R&TTE-Direktive 1999/5/EC entsprechen.

Zur sachgemäßen Umsetzung der in den EG-Richtlinien genannten Anforderungen wurden  
folgende Normen herangezogen:

conform to the basic requirements of EEC Directive 89/336/EEC resp. R&TTE Directive 1999/5/EC.

To effect correct application of the requirements stated in the EEC Directives,  
the following standards were consulted:

sont conformes aux prescriptions fondamentales dans la Directive de la CEE 89/336/EEC or  
la Directive R&TTE 1999/5/EC.

Pour mettre en pratique dans la règle de l'art les prescriptions des Directives de la CEE, il a été  
tenu compte des normes suivantes:

complen los requimientos básicos de la normativa de la CEE 89/336/EEC resp. de la  
normativa R&TTE 1999/5/EC.

Con il fin de realizar de forma adecuada los requerimientos referidos en las normativas de  
la CEE fueron consultadas las siguientes normativas:

sono conformi alla normativa 89/336/EEC resp. alla normativa R&TTE 1999/5/EC.

Per un'opportuno risconto nell'ambito della normativa CEE sono state consultate le seguenti normative:

eveneekomt met de basiseisen van de EG-Richtlijn 89/336/EEC resp. de EG-Richtlijn 1999/5/EC.

Om de eisen, die in de EG-Richtlijnen vermeld zijn, in juiste vorm om te zetten,  
zijn van volgende normen gebruik gemaakt:

**ETS 300 445**

**ETS 300 422**

Wedemark, Oct, 2003



Klaus Willemsen  
Key Projects  
Product Marketing

**Bemerkung:**

Vor Inbetriebnahme sind die jeweiligen länderspezifischen Vorschriften zu beachten!

**Important:**

Before putting the device into operation, please observe the respective country-specific regulations!

**Important:**

Avant d'utiliser l'appareil, veuillez observer les dispositions légales en vigueur dans votre pays.

**Nota:**

Prima della messa in funzione seguite le prescrizioni vigenti nel paese nel quale viene utilizzato!

**Observación:**

!Anterior a la puesta en funcionamiento deberán observarse las correspondientes ordenanzas nacionales!

**Opmerking:**

Voor inbedrijfstelling dient u de afzonderlijke landspecifieke voorschriften in acht te nemen!

**CE 0682** 



Sennheiser electronic GmbH & Co. KG  
30900 Wedemark, Germany  
Phone +49 (5130) 600 0  
Fax +49 (5130) 600 300  
[www.sennheiser.com](http://www.sennheiser.com)